



***OWNER'S MANUAL
SUPPLEMENT***

2002

LPG CHEVROLET EXPRESS AND GMC SAVANA

QUANTUM® LPG Owner's Manual Supplement

- Section 1** **Features and Controls**
This section explains how to start and operate your vehicle.
- Section 2** **Your Driving and the Road**
This section tells you about operating your vehicle under different conditions.
- Section 3** **Problems on the Road**
This section tells you what to do if you have a problem on the road.
- Section 4** **Service Care**
Here the manual tells you how to keep your vehicle running properly.
- Section 5** **Maintenance Schedule**
This section tells you when to perform vehicle maintenance.
- Section 6** **Customer Assistance Information**
This section tells you how to contact QUANTUM® for assistance.
- Section 7** **Index**
Here's an alphabetical listing of every subject in this manual.

GENERAL MOTORS, GM, the GM Emblem, CHEVROLET, the CHEVROLET Emblem, the name EXPRESS, GMC, the GMC Emblem and the name SAVANA are registered trademarks of General Motors Corporation and are used herein with the permission of General Motors Corporation.

This manual includes the latest information at the time it was printed. We reserve the right to make changes in the product after that time without further notice

Please keep this manual in your vehicle, so it will be there if you ever need it when you're on the road. If you sell the vehicle, please leave this manual in it so the new owner can use it.

Litho in U.S.A.
103484 A First Edition

©Copyright QUANTUM Technologies, Inc. 2001
All Rights Reserved

Introduction

Your vehicle is designed to operate on Liquefied Petroleum Gas (LPG), also known as propane. There are abundant reserves of propane in the United States and Canada. When propane is burned in your engine, it produces low emissions. This means less smog, less air pollution and cleaner air. This makes propane a promising motor fuel for the future.

How to Use this Supplement

This supplement contains information specific to the LPG fuel system on your vehicle. It doesn't explain everything you need to know about your vehicle. **You must use this supplement along with your GM owner's manual.** Only then will you be able to properly operate and maintain your vehicle.

Please read this supplement from beginning to end when you first receive your new vehicle. If you do this, it will help you learn about the special features and controls. In this supplement, you'll find that words and pictures work together to make things easy to understand.

Index

A good place to look for what you need is the Index in the back of this supplement. It's an alphabetical list of all that's in the supplement, and the page number where you'll find it.

Model Reference

This supplement contains information that covers
G-Van Series Savana and Express models.

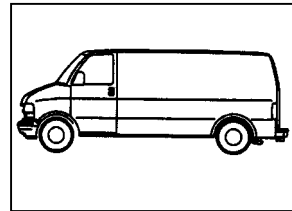
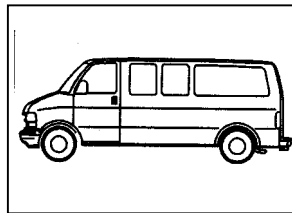

Section 1 Features and Controls

This section explains how to start and operate your vehicle.

- 1-2 Starting Your LPG Vehicle
- 1-3 Restarting Your LPG Vehicle While Moving (Automatic Transmission)
- 1-3 Wait to Drive Light
- 1-4 Cold Weather Operation
- 1-4 Malfunction Indicator Lamp

Starting Your LPG Vehicle

Your vehicle is designed to start and operate on LPG.

Starting Your Engine

1. Move your shift lever to PARK (P) or NEUTRAL (N). Your engine won't start in any other position – that's a safety feature. To restart when you're already moving, use NEUTRAL (N) only.
2. Without pushing the accelerator pedal, turn your ignition key to START. When the engine starts, let go of the key. The idle speed will go down as your engine gets warm.

NOTICE:

Holding your key in START for longer than 15 seconds at a time will cause your battery to be drained much sooner. And the excessive heat can damage your starter motor.

3. If the engine doesn't start right away, hold your key in START and crank the engine for 10 more seconds, unless it starts sooner. When the engine starts, let go of the key.
4. If your engine still won't start, check for the following conditions:
 - The LPG fuel tank is empty.
 - An LPG fuel system fuse is bad. See "Fuses" in the Index.
 - The LPG manual shut-off valve (MSV) is closed. See "LPG Manual Shut-off Valve (MSV)" in the Index.If none of these conditions exists, your vehicle may require service.

LPG Engine Warm-Up

When you've started your engine, let it run for 20 or 30 seconds to warm-up before you put a load on the engine.

Drive at moderate speeds for the first few miles, especially in cold weather. Running a cold engine at high speed can damage it.

Restarting Your LPG Vehicle While Moving (Automatic Transmission)

If you have to restart the engine while the vehicle is moving, you'll have to shift the automatic transmission to NEUTRAL (N). This safety feature prevents starting the engine when the transmission is in a drive gear.

Wait to Drive Light

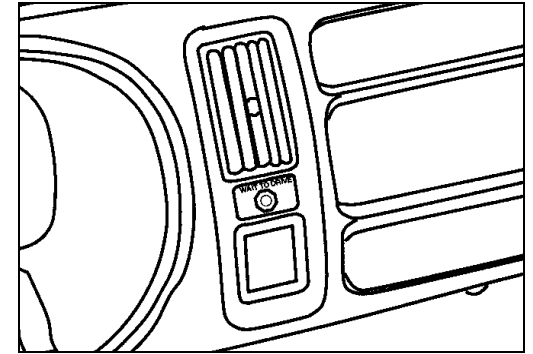

The wait to drive light is located at the right of the instrument panel cluster.

This light will come on when you first start your vehicle in very cold weather. When the light is on, the engine will idle only. If you try to drive your vehicle, the engine will stall. This is a safety feature and allows the LPG fuel system to reach operating temperature. Wait until the light goes out before driving your vehicle.

Cold Weather Operation

For better cold weather starting and warm-up, you can do the following:

- Move the vehicle to a warm garage area.
- Use an engine coolant heater. Refer to “Engine Coolant Heater” in the Index of your GM owner’s manual.

Malfunction Indicator Lamp (Service Engine Soon Light)

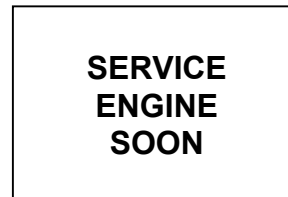

Your vehicle is equipped with a computer that monitors the operation of the LPG fuel system. If the computer detects a fuel system problem, the SERVICE ENGINE SOON light will illuminate. Your vehicle may require service. See “Malfunction Indicator Lamp” in the Index of your GM owner’s manual.

Section 2 Your Driving and the Road

This section tells you about operating your vehicle under different conditions.

2-2 Trailer Towing

2-3 Tank Cover

Trailer Towing

	CAUTION:
Do not install an aftermarket frame-mount trailer hitch on your vehicle. This may damage the LPG fuel system and cause a leak. You or someone else could be injured. Only use a QUANTUM factory installed trailer hitch.	

	CAUTION:
Do not exceed the maximum weight rating of your QUANTUM factory installed trailer hitch. For example, if your trailer is too heavy, your vehicle may be difficult to control. You or your passengers could be injured.	

Do not install an aftermarket frame-mount trailer hitch on your vehicle. An aftermarket hitch may interfere with the LPG fuel tank, tank brackets or fuel lines.

If you tow a trailer with your vehicle, only use a QUANTUM factory installed trailer hitch. This factory installed hitch is designed for use with the LPG fuel system.

The QUANTUM trailer hitch is rated as follows:

Maximum Trailer Weight 2000 lbs (908 Kg)

Maximum Trailer Tongue Weight 200 lbs (91 Kg)

Tank Cover



CAUTION:

Do not remove the LPG fuel tank cover and then drive your vehicle. Road debris may damage the LPG fuel system components and cause a leak. You or someone else could be injured.

Your vehicle has an LPG fuel tank mounted under the body at the rear of the vehicle. A cover protects the tank from damage by road debris. The tank should only be removed for service. Do not remove the cover and then drive your vehicle

Section 3 Problems on the Road

This section tells you what to do if you have a problem on the road.

3-2 LPG Manual Shut-off Valve

3-2 In Case of a LPG Leak

3-3 Jump Starting

3-3 Towing Your Vehicle

LPG Manual Shut-off Valve (MSV)

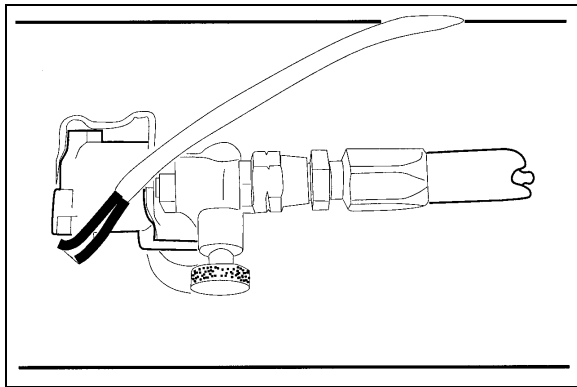

The LPG manual shut-off valve (MSV) is located on the LPG fuel tank. You can reach the MSV through the access hole on the bottom of the LPG fuel tank cover.

To close the valve and shut-off fuel, turn the thumbscrew clockwise. To open the valve, slowly turn the thumbscrew counterclockwise. Always operate your vehicle with the MSV fully open.

The MSV has an internal excess flow valve. Under certain conditions, this valve will close and stop fuel flow. This can happen if the fuel lines are empty and the MSV is opened too quickly. To reset the excess flow valve, close the MSV and then slowly open it.

In Case of a LPG Leak

It's normal to smell a slight LPG odor right after you turn-off your vehicle. However, if you smell a persistent LPG odor or hear a hissing sound, the LPG fuel system on your vehicle might have a leak. Turn the manual shut-off valve on the LPG fuel tank clockwise to close the valve. See "LPG Manual Shut-off Valve (MSV)" in this section. Have the vehicle towed to an authorized LPG service facility.

Jump Starting



CAUTION:

If the LPG fuel system has a leak, a spark from jumper cables could ignite the LPG. You or someone else could be badly burned. Do not jump start your vehicle if you smell LPG or hear a hissing sound.

Before jump starting your vehicle, check for a LPG leak. If you smell a persistent LPG odor or hear a hissing sound, the LPG fuel system on your vehicle might have a leak. Do not try to jump start your vehicle. Turn the manual shut-off valve on the LPG fuel tank clockwise to close the valve. See “LPG Manual Shut-off Valve” in this section. Have the vehicle towed to an authorized LPG service facility.

See “Jump Starting” in the Index of your GM owner’s manual for step by step jump starting instructions.

Towing Your Vehicle



CAUTION:

Towing your vehicle with improperly positioned tow straps, hooks or chains can damage the LPG fuel system and cause a leak. You or someone else could be injured. Do not use the LPG fuel system components and/or fuel lines as towing attachment points.

To prevent damage to the LPG fuel system, use only the attachment points shown in the GM owner’s manual. See “Towing Your Vehicle” in the Index of your GM owner’s manual for towing instructions.

Section 4 Service Care

Here the manual tells you how to keep your vehicle running properly.

- 4-2 Doing Your Own Service Work
- 4-2 Fuel (LPG Vehicle)
- 4-2 Filling Your LPG Fuel Tank
- 4-5 Fuel Filling Problems
- 4-5 Fuses and Circuit Breakers
- 4-6 Capacities and Specifications

Doing Your Own Service Work



CAUTION:

Never try to do your own service work on the LPG fuel system. The LPG fuel system operates under high pressure. You could be injured and your vehicle damaged if you try to do service work. Service and repair of the system should only be performed by a trained LPG service technician with the proper knowledge and tools.

Fuel (LPG Vehicle)

It is recommended that you use only HD-5 grade LPG . This fuel grade will provide improved driveability and emission control system performance compared to other grades, especially in cold weather.

LPG that does not meet these specifications may cause fuel system or engine damage. Repairs may not be covered under warranty.

Filling Your LPG Fuel Tank



CAUTION:

Liquefied Petroleum Gas (LPG) is extremely flammable. If something ignites it, you could be badly burned. Keep sparks, flames and smoking materials away from LPG. Do not smoke if you are near LPG or refueling your vehicle.



CAUTION:

Liquefied Petroleum Gas (LPG) is stored in the fuel tank at pressures up to 312 psi (2.2 MPa). To prevent personal injury, never:

- Fill to a pressure greater than 312 psi (2.2 MPa).
- Fill a leaking or damaged tank.



CAUTION:

Liquefied Petroleum Gas (LPG) can cause severe cold burns and frostbite. Never let liquid LPG contact your skin or eyes. When filling your LPG fuel tank, always wear gloves approved for handling LPG and appropriate eye protection.



CAUTION:

If your vehicle is parked on an angled surface, the auto-stop fill device may not function correctly. If the tank is overfilled, the pressure relief device (PRD) may open. You could be injured. Make sure your vehicle is parked on a level surface when filling the LPG fuel tank

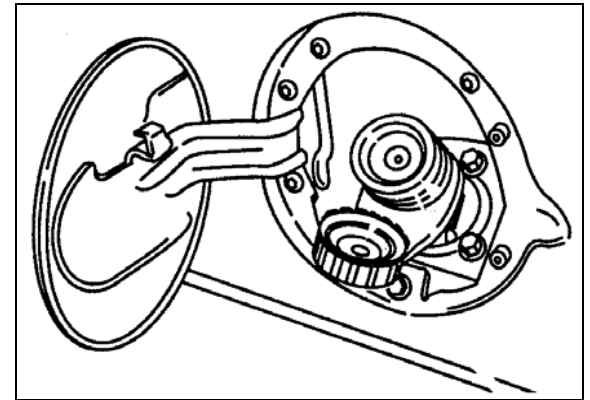

The LPG fill valve is located on the left side of your vehicle.

Unless you are experienced with filling a LPG fuel tank, consult a qualified LPG station operator.

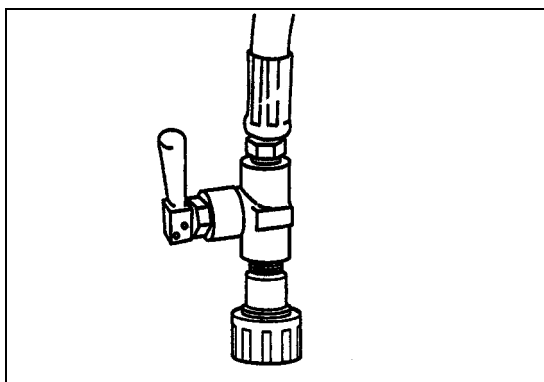

Here is a fuel filling procedure using a typical LPG fill nozzle:

1. Turn off the engine and set the parking brake.
2. Remove the fill valve cap. Turn it to the left (counterclockwise).
3. Inspect the fill valve seal. Make sure the seal is seated in the groove. Never connect the fill nozzle to the valve if the seal is missing or damaged. The seal must be replaced. See "Fill Valve Seal" in the Index.
4. Connect the LPG fill nozzle to the valve.
5. Flip the fill nozzle lever 90° to lock the nozzle.

6. Open the liquid level gauge (80% fill / "spitter") valve on the LPG fuel tank.
7. Start the LPG fuel pump to begin refueling.
8. When LPG has stopped transferring or white vapor escapes from the remote outage valve, close the fuel supply valve.
9. Close the liquid level gauge (80% fill / "spitter").
10. Flip the fill nozzle 90° to unlock the nozzle.
11. Disconnect the fill nozzle.
12. Return the fill nozzle to the dispenser.
13. Install the fill valve cap. Turn it to the right (clockwise).

Fuel Filling Problems

Under certain conditions, you may notice it takes longer to fill your LPG fuel tank on a hot day. This is caused by an increase in the pressure inside the tank. This is normal and does not indicate a problem with the tank.

If you notice very slow fill rates, a decrease in tank capacity or are unable to fill your LPG fuel tank, the tank may require service. Take your vehicle to an authorized LPG repair facility for service.

Fuses and Circuit Breakers

The LPG fuel system wiring in your vehicle is protected from short circuits by a two fuses. These fuses are located in the engine compartment fuse relay center.

If this fuse is bad, your vehicle will not start. Be sure to replace this fuse with a fuse of the same rating. Do not use a fuse of higher amperage.

Engine Compartment Fuse Relay Center

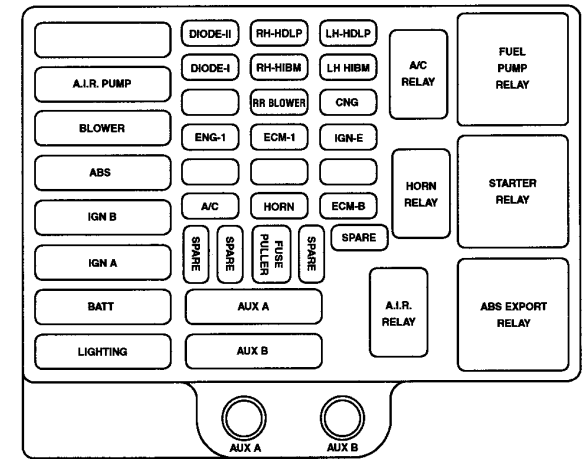

NAME	CIRCUITS PROTECTED
ECM-1	LPG Fuel System Ignition Power
CNG	LPG Fuel System Battery Power

Capacities and Specifications

Cooling System Capacity (Approximate)

ENGINE	VIN	QTY Without Rear Heater	QTY With Rear Heat
“VORTEC” 5700 V8 with LPG	R	18.0 Quarts (17.0 L)	21.0 Quarts (19.9 L)

After refill, the level MUST be checked. See “Engine Cooling System” in the Index of your GM owner’s manual.

Crankcase Capacity (Approximate)

ENGINE	VIN	QTY With Filter
“VORTEC” 5700 V8 with KL5	R	6.0 Quarts (5.6 L)

After refill, the level MUST be checked. See “Engine Oil” in the Index of your GM owner’s manual.

LPG Fuel Tank Capacity (Approximate)

29.0 Gallons (109.8 L)

Normal Maintenance Replacement Parts

Service Replacement Part and Filter Recommendations

LPG Fuel Filter	F4-20804-001
-----------------	--------------

Section 5 Maintenance Schedule

This section tells you when to perform vehicle maintenance.

- 5-2 Part A: Scheduled Maintenance Services
- 5-3 Part B: Owner Checks and Services
- 5-4 Part C: Maintenance Record

Part A: Scheduled Maintenance Services

Maintenance Schedule

The following maintenance items are specific to the LPG fuel system on your vehicle. These items are required *in addition to* the maintenance items listed in your GM owner's manual.

The services shown in this schedule should be performed after 100,000 miles (166 000 km) at the same intervals.

30,000 Miles (50 000 km)

- Inspect intake system for vacuum leaks.
- Replace LPG fuel filter (or every 12 months, whichever occurs first). (3)
- Check all vacuum lines and fittings.
- Check all fuel lines and fittings.

60,000 Miles (100 000 km)

- Check intake system for vacuum leaks.
- Check converter / check regulator primary and secondary pressures. (61)
- Replace LPG fuel filter (or every 12 months, whichever occurs first). (3)
- Check all vacuum lines and fittings.
- Check all fuel lines and fittings.
- Replace spark plugs and perform ignition system inspection. (28)
- Perform mixer air valve service. (60)

90,000 Miles (150 000 km)

- Check intake system for vacuum leaks.
- Replace LPG fuel filter (or every 12 months, whichever occurs first). (3)
- Check all vacuum lines and fittings.
- Check all fuel lines and fittings.

120,000 Miles (166 000 km)

- Check intake system for vacuum leaks.
- Check converter / check regulator primary and secondary pressures. (61)
- Replace LPG fuel filter (or every 12 months, whichever occurs first). (3)
- Check all vacuum lines and fittings.
- Check all fuel lines and fittings.
- Replace spark plugs and perform ignition system inspection. (28)
- Perform mixer air valve service. (60)

FOOTNOTES

- (3) = An Emission Control Service.
- (28) = Remove and replace the spark plugs. Inspect the spark plug wires for damage. Check the spark plug wire connections at the plug and at the distributor. Inspect the wire harness connections at the distributor. Repair or replace parts as necessary.
- (60) = Remove the mixer cover and spring from the mixer. Remove the air valve assembly from the mixer body. Inspect for dirt, oil contamination or damage. Clean or repair as necessary.

- (61) = If primary and secondary pressures are within specification, no further action is necessary. If pressures are out of specification, remove converter cover, spring and diaphragm. Inspect for dirt, oil contamination or damage. Clean or repair as necessary.

Part B: Owner Checks and Services

At Each Fuel Fill

Fill Valve Seal

Inspect the fill valve seal. Make sure the seal is seated in the groove. Replace if missing or damaged.

At Least Twice a Year

Low Pressure Regulator (LPR) Coolant Hoses

Inspect the LPR coolant hoses twice a year (for example, spring and fall). Have the hoses replaced if they are cracked, swollen or deteriorated. Inspect all fittings and clamps; replace if necessary.

At Least Once a Year

LPG Fuel System Leak Inspection

Inspect the LPG fuel system for leaks once a year using a liquid or an electronic leak detector. If a leak is found, repair or replace the component as required.

Part C: Maintenance Record

After the scheduled services are performed, enter the date, odometer reading and services performed on the maintenance record charts provided here. Any additional information from “Owner’s Checks and Services” can be added on the following record pages.

Maintenance Record			
DATE	ODOMETER READING	SERVICED BY	MAINTENANCE PERFORMED

Section 6 Customer Assistance Information

This section tells you how to contact QUANTUM® for technical assistance.

6-2 Technical Assistance

6-3 Parts and Service

6-2 Warranty Claims

Technical Assistance

For LPG fuel system technical assistance, contact:

QUANTUM Technologies, Inc.
17872 Cartwright Road
Irvine, CA 92614
1-800-816-8691

Parts and Service

For parts orders, the location of the nearest authorized service center, a service parts book or a labor time guide, contact:

QUANTUM Technologies, Inc.
17872 Cartwright Road
Irvine, CA 92614
1-888-90-IMPCO (904-6726)

Warranty Claims

For dealers or fleets performing warranty repairs, submit an invoice or work order to the following address. Be sure to include your standard hourly labor rate.

QUANTUM Technologies, Inc.
17872 Cartwright Road
Irvine, CA 92614

Attn: LPG G Van Warranty Claims Processing

Section 7 Index

Capacities and Specifications.....	4-6	Owner Checks and Services.....	5-3
Cold Weather Operation	1-4	Parts and Service	6-2
Doing Your Own Service Work.....	4-2	LPG Manual Shut-off Valve.....	3-2
Filling Your LPG Fuel Tank.....	4-2	Restarting Your LPG Vehicle While Moving (Automatic Transmission).....	1-3
Fuel (LPG Vehicle).....	4-2	Scheduled Maintenance Services	5-2
Fuel Filling Problems.....	4-5	Starting your LPG Vehicle.....	1-2
Fuses and Circuit Breakers.....	4-5	Tank Cover.....	2-3
Engine Compartment Fuse/Relay Center.....	4-5	Technical Assistance.....	6-2
How to Use This Supplement	iii	Trailer Towing	2-2
In Case of a LPG Leak	3-2	Towing Your Vehicle.....	3-3
Index	iii	Wait to Drive Light.....	1-3
Introduction.....	iii	Warranty Claims	6-2
Jump Starting	3-3		
Maintenance Record	5-4		
Malfunction Indicator Lamp	1-4		
Model Reference	iv		

